

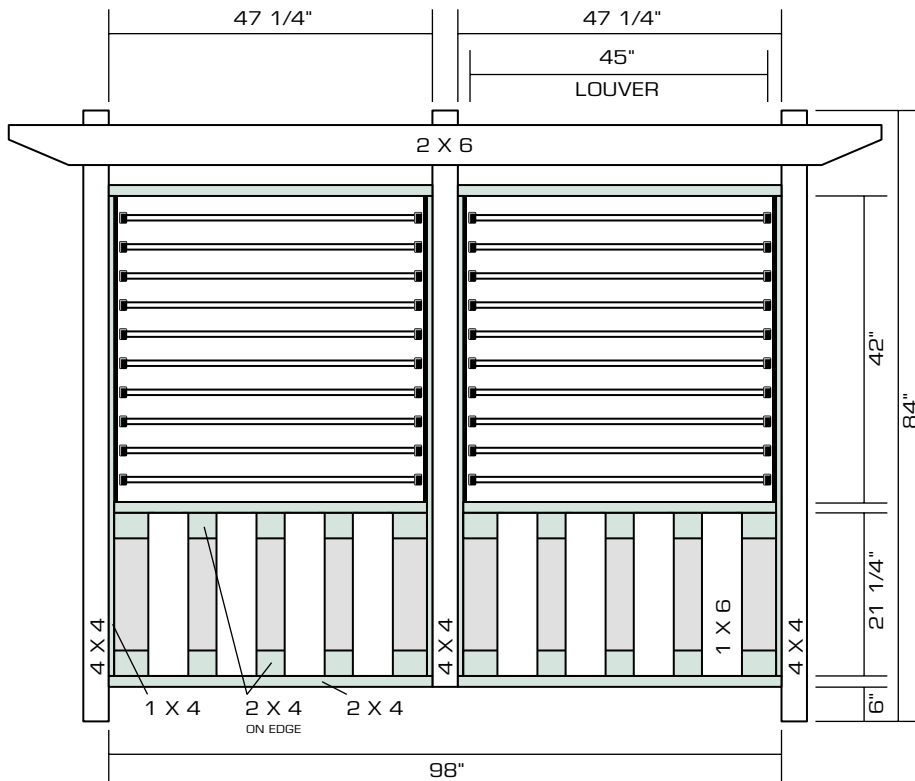



# Fully Louvered Fence

[www.flexfence.com](http://www.flexfence.com)



-  BOARDS STAGGERED OTHER SIDE
-  EASY BUILD FRAME BETWEEN POSTS

## MATERIAL LISTING

1. 2/kits FLEX·fence. Cut the kit to 42" (leave 3" space from pre-punched holes on each end)
2. 2/pcs - 4" x 4" x 84"
3. 1/pcs - 4" x 4" x 77"
4. 18/pcs - 1" x 6" x 21 1/4"
5. 20/pcs - 1" x 6" x 45"
6. 10/pcs - 2" x 4" x 46 1/4"
7. 1/pcs - 2" x 6" x 120"
8. 4/pcs - 1" x 4" x 64"
9. 2" Spiral nails
10. Exterior grade carpenter's glue

## TOOLS REQUIRED

1. Pencil
2. Measuring Tape
3. #1 Robertson Screw Driver-Green Handle or (Philips Screw Driver)
4. #2 Robertson Screw Drive-Red Handle (Philips -Screw Driver)
5. Hand Saw
6. Hammer
7. Chisel
8. Combination Square
9. Protective Eyewear
10. Level

## OPTIONAL TOOLS

- \* Drill with appropriate bits & counter sink bit
- \* Router with decorative bits
- \* Power saws - Mitre & Skill

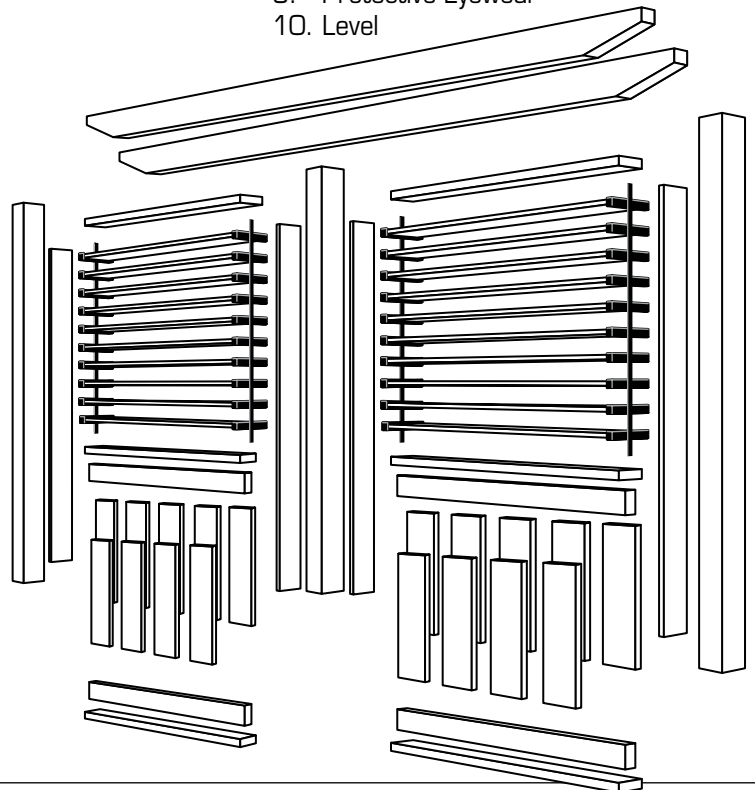

Visit [www.flexfence.com](http://www.flexfence.com) for updates, other project plans and photos from professionals and backyard pros.